

Environmental

Compliant with
BS EN-12566 Part 3



Klargester Biosafe
Package Sewage Treatment System



Sustainable, Reliable, Affordable



Klargester Biosafe

The best designs are the simplest. So if you require trouble free sewage treatment, you're sure to be impressed with the new Biosafe.

Fluidised, fixed-film biozones are used as the operating process, resulting in a cleaner, quieter and more efficient treatment plant.

Benefits

- Unobtrusive below ground installation
- Suitability for varying invert levels
- 450 and 750mm invert options
- Excellent durability
- Low profile results in shallow depth excavation
- Simple maintenance with easy desludging
- Pumped discharge option available
- Compliant with BS EN-12566 Part 3
- Proven standards of discharge - 20mg/l BOD, 30mg/l S.S. and 10mg/l Ammonia in domestic applications

A new generation of treatment plants for treating domestic sewage waste in a compact system of three separate stages within a 'unitank' design. The fluidised fixed-film biozone process provides an extremely robust means of reducing ammoniacal nitrogen.

Raw sewage flowing to the unit is received in the primary settlement zone. Gross solids settle to the bottom. The residual effluent (supernatant liquor) is displaced from the primary stage into the two-stage biozone.

Flow circulation in the biozone is generated by the effect of a fine bubble system. During several passes through the beds, the supernatant liquor is purified by naturally occurring micro organisms (biomass) that grow on the media. The liquid displaced to the outlet is treated, and known as final effluent.

Product Specification

Unit Inlet Invert Ref. (mm)	A Outlet (mm)	B Overall Length (mm)	C Height (incl. feet) (mm)	D Ducting Invert (mm)	E Overall Diameter (mm)
450	550	2720	1700	250	1530
750	850	2720	2000	550	1530

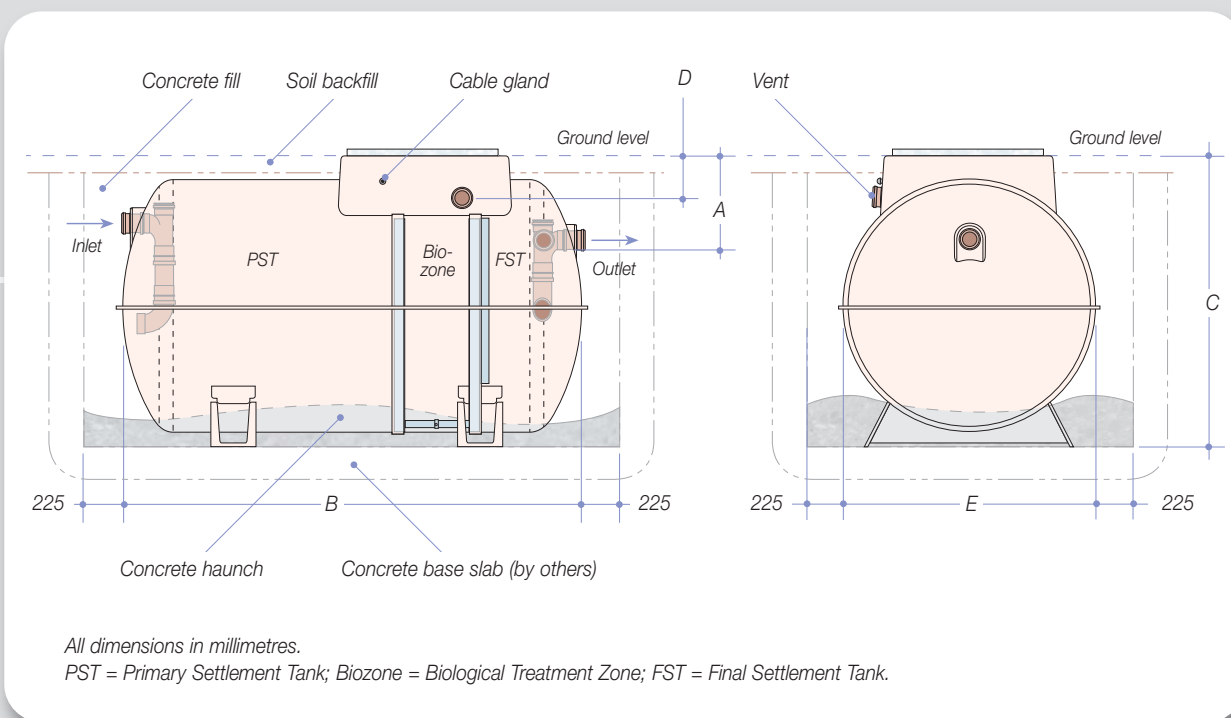



Inlets, outlets and power supply connections are clearly marked on the tank exterior



New skid-resistant tread pattern and stainless steel locking device features on the cover



Easy access for desludging.

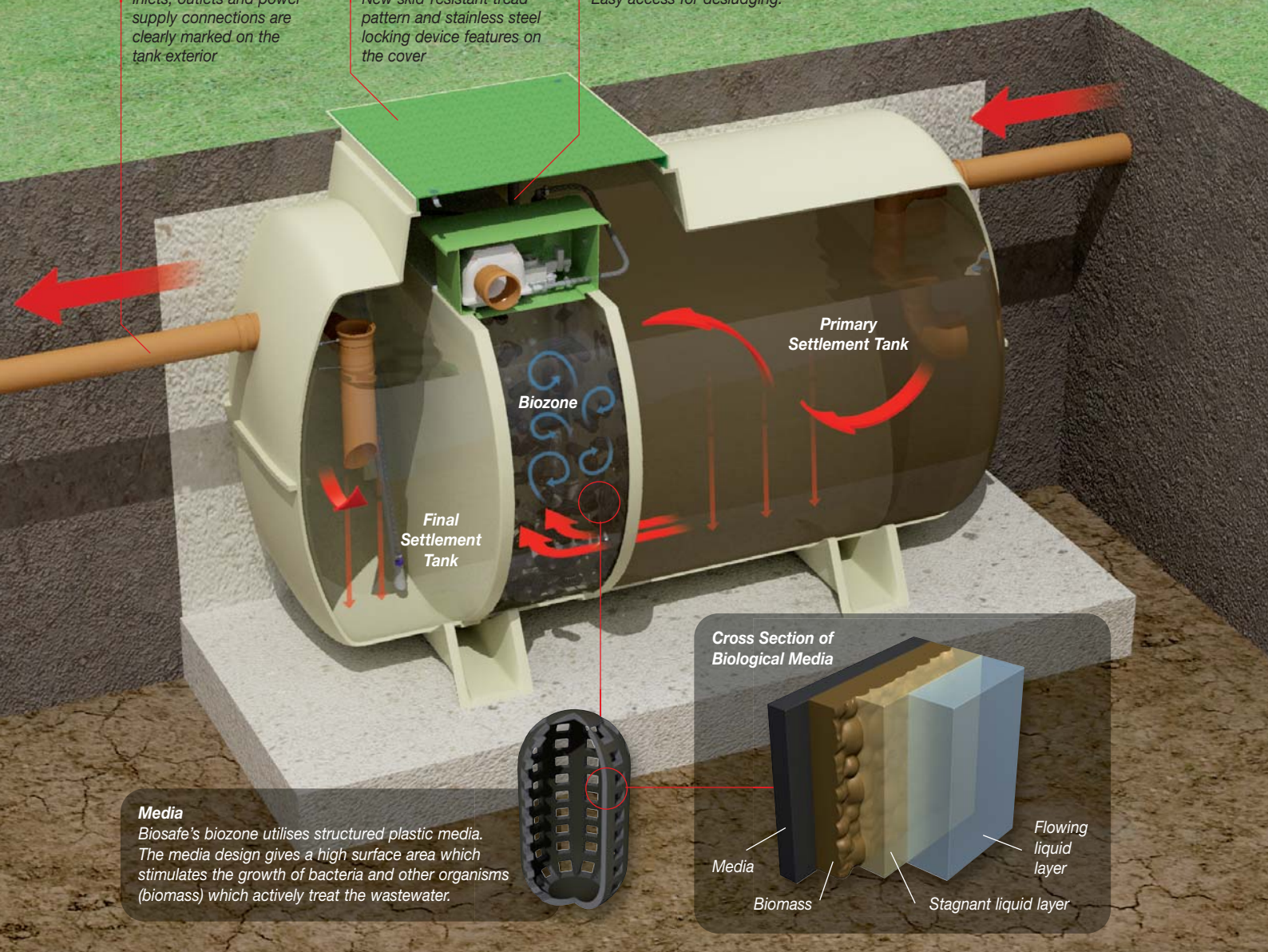

Media

Biosafe's biozone utilises structured plastic media. The media design gives a high surface area which stimulates the growth of bacteria and other organisms (biomass) which actively treat the wastewater.

Cross Section of Biological Media

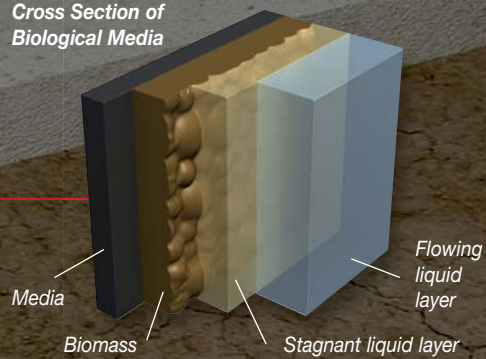

Pumped Outlet Option

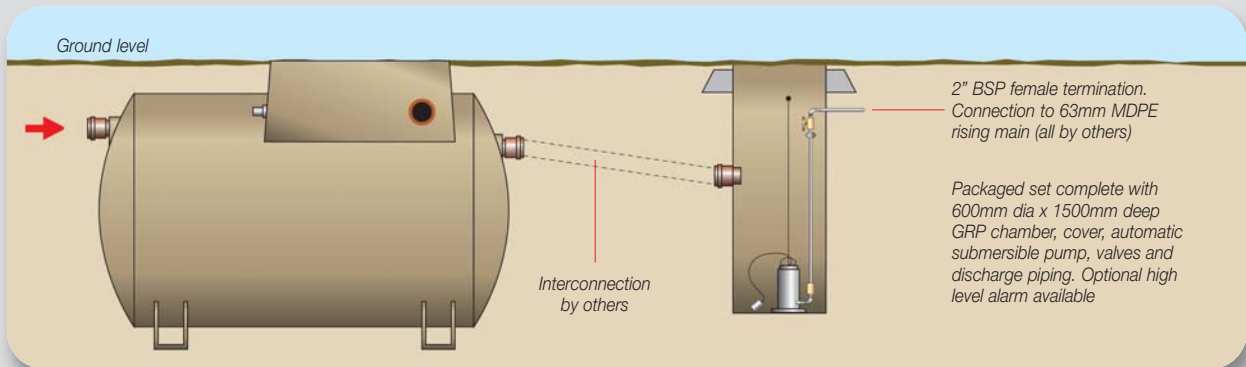

Kingspan Environmental Solutions



Commercial Sewage Treatment Plants



Large Capacity Pumping Stations

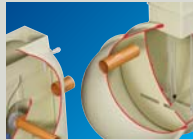

Stormwater Attenuation Systems



Residential & Commercial Rainwater Harvesting

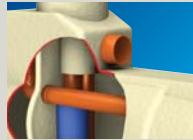

Oil/Water Separators

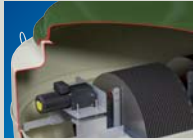

Domestic Sewage Treatment Plants



Packaged Pump Systems



Reed Beds



Domestic Rainwater Harvesting

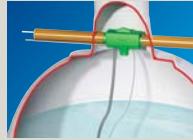

Garden Watering Systems



Septic Tanks



Below Ground Storage Tanks



Grease & Silt Traps



Packaged Drainage Systems

Klargester Environmental Approved Installers

Strategically located throughout the UK and Ireland, Klargester Environmental Approved Installers are appointed following a selection process which assesses their installation expertise, reputation and financial status.

These performance criteria, together with their design skills and knowledge of Klargester Environmental products are also reviewed to ensure that the highest levels of professionalism are maintained.

Larger Applications

Klargester Environmental also manufactures a range of larger plant (for example BioDisc® BE-BL models) to cater for larger applications such as residential developments, caravan sites and hotels.

As specialists in wastewater treatment we are able to provide solutions for many different applications. Please contact us for further information.

Kingspan Environmental Service

Who better to look after your wastewater product than the people who designed and built it?

Kingspan Environmental have a dedicated service division providing maintenance for wastewater and rainwater products.

Factory trained engineers are available for site visits as part of a planned maintenance contract or on a one-off call out basis.

To find out more about protecting your investment and ensuring peace of mind, contact us on **(NI) 028 302 54077, (IRL) 048 302 54077** or visit us online at **www.kingspanenvservice.com**



Accredited to
BS EN ISO 9001: 2008
BS OHSAS 18001: 2007



Klargester Environmental

Ireland: Unit 1a, Derryboy Road, Carnbane Business Park, Newry, Co. Down BT35 6QH
(NI) Tel: +44 (0) 28 302 66799 Fax: +44 (0) 28 302 60046
(IRL) Tel: 048 302 66799 Fax: 048 302 60046
email: info@klargester.ie

Visit our website **www.klargester.ie**, or our company website **www.kingspanenv.com**

Klargester is part of Kingspan Environmental.

In keeping with Company policy of continuing research and development and in order to offer our clients the most advanced products, Kingspan Environmental reserves the right to alter specifications and drawings without prior notice.