

Introducing the new
BETA+ SEPTIC TANK



 **Klargester** - Moulding the future of septic tanks

Data Sheet: Klargester Beta+ Septic Tank

Shallow-dig polyethylene septic tank for domestic applications



Features and benefits

- Shallow-dig due to modern design
- Robust, impact resistant polyethylene construction
- Wide neck with securable manhole cover provides easy access for desludging
- Integral safety device to prevent accidental entry
- Variable invert neck – 0.9 to 0.5 metre
- Moulded lifting points for safe delivery, off-loading and installation
- Extension neck available for deeper installations

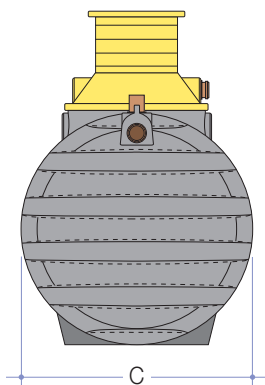
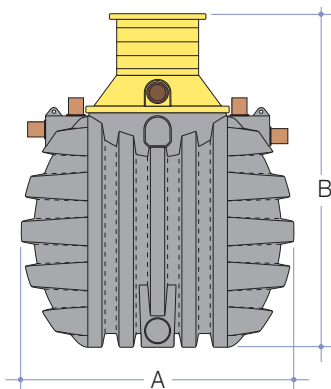

Super Tough Construction

High resistance to impact makes the **Beta+** tank ideal for rocky strata conditions.

No more handling worries!



Shallow Dig

The squat shape of the **Beta+** means minimal excavation and shallow-dig. High structural strength means concrete backfill is only required in 'wet sites'.



Proven Performance

Under EN-12566 (Part 1) testing **Beta+** retained 99% of sewage solids in the tank.

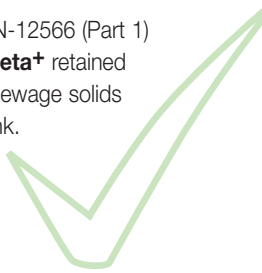

Simpler Range

Beta+ is a septic tank designed for modern living. Revised sizing and reduced range simplifies selection and stocking.

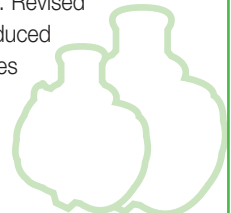

Specification

| Model Reference | Capacity (litres) | Population equivalent | Length A (mm) | Height B (mm) | Width C (mm) |
|-----------------|-------------------|-----------------------|---------------|---------------|--------------|
| STP030K | 3,080 | 6 | 2000 | 2443 | 1700 |
| STP041K | 4,160 | 12 | 2400 | 2543 | 1800 |

Klargester

UK: College Road North, Aston Clinton, Aylesbury, Buckinghamshire HP22 5EW
Tel: +44 (0) 1296 633000 Fax: +44 (0) 1296 633001 Scottish Office: Tel: +44 (0) 1355 248484
email: info@klargester.com

Ireland: Unit 1a, Derryboy Road, Carnbane Business Park, Newry, Co. Down BT35 6QH
NI Tel : +44 (0) 28 302 66799 Fax: +44 (0) 28 302 60046 ROI Tel: 048 302 66799 Fax: 048 302 60046
email: info@klargester.ie

www.klargester.com

Kingspan Environmental reserves the right to change specification or design and supply products which may differ from those described and illustrated without notice and without liability.

Part of

www.kingspanenv.com